

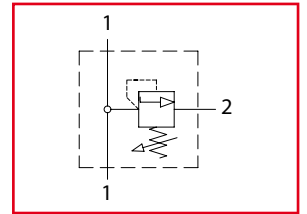

VMDR40

Valvole di massima pressione in linea
Direct acting relief valves



LEHENGOK, S.A.



Dati tecnici Technical data	
Viscosità fluido Fluid viscosity	10-500 mm ² /s 45 to 2000 ssu (6 to 420 cSt)
Classe di contaminazione Filtration	ISO code 16/13 SAE class 4 or better
Temperatura fluido Fluid temperature	-20°C +80°C -4°F +176°F
Temperatura ambiente Ambient temperature	-20°C +50°C -4°F +122°F

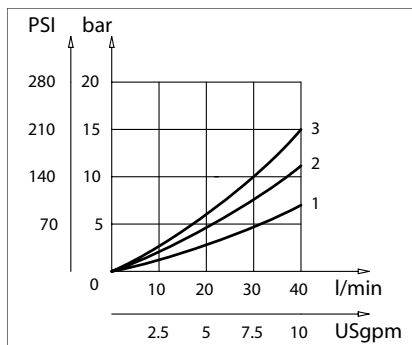
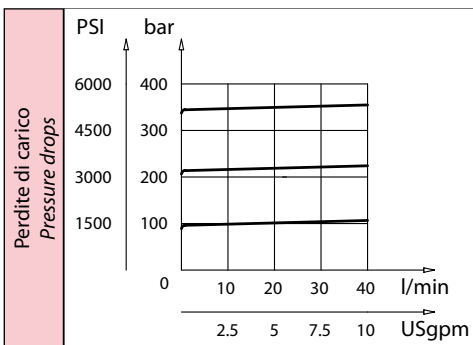
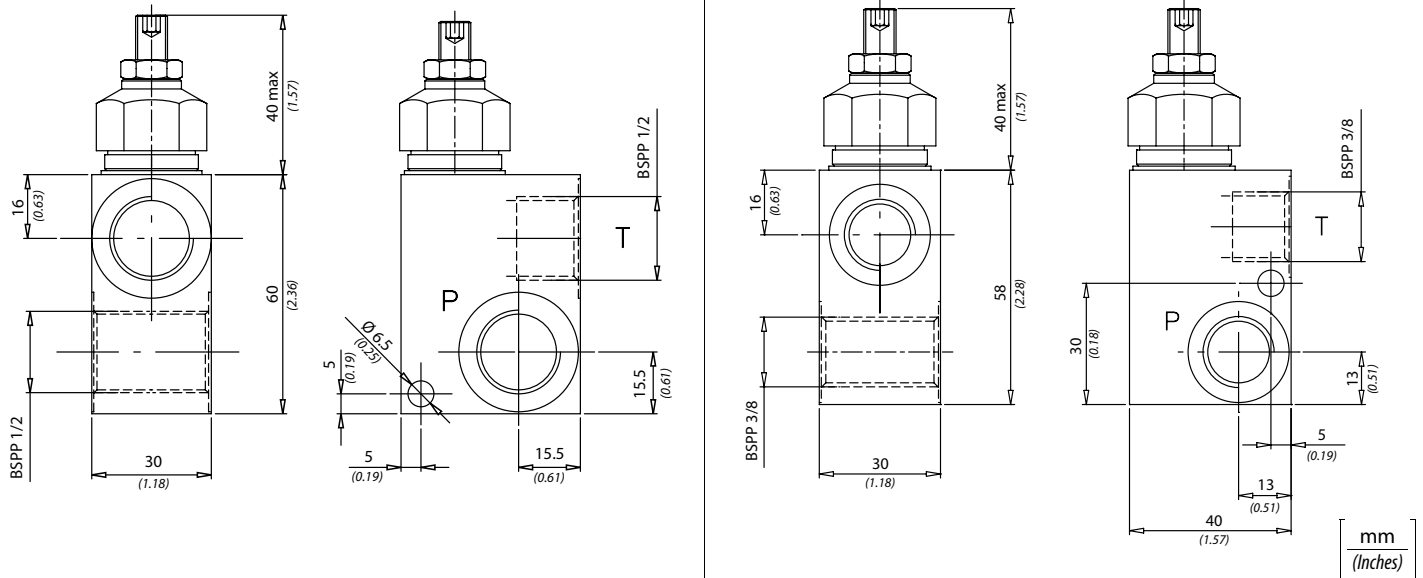
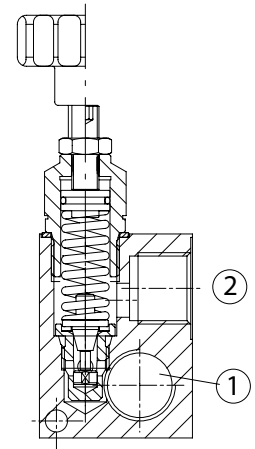

Caratteristiche tecniche Technical performances			
Codice Code	Portata Max Max flow l/min - USgpm	Pressione Max Max pressure bar/PSI	Peso approssimativo Approx weight Kg / lb
VMDR40380	40 (10)	300 (4350)	0,50 (1.1)
VMDR40120			0,53 (1.2)

Codice ordinazione Ordering code			
VMDR40 - X - Y - K			
X	Dimensione / Size	Y	Regolazione / Setting
380	BSPP 3/8	C	
120	BSPP 1/2		
K	Molla - Spring		
1	110 bar (1450 PSI) max	V	
2	210 bar (3000 PSI) max		
3	300 bar (4350 PSI) max		
S		S	