

# GLOBE VALVES

**CLASS 800-1500**

WELDED BONNET - Full and reduced bore



**LEHENGOMAK, S.A.**

Design construction:  
 BS 5352 - NF M87.412  
 Testing according to API 598 - BS 6755  
 Marking MSS SP25

Outside Screw and Yoke (OS&Y)  
 Self aligning packing gland in two parts  
 Integral backseat  
 Body bonnet weld to ASME IX  
 Loose solid disc

Socket weld Ends to ANSI B16.11  
 Screwed Ends (NPT) to ANSI B1.20.1  
 Butt Welding Ends to ANSI B.16.25

Ratings:  
 - carbon steel class 800 1975 psig @ 100°F  
 138 bar + 38°C  
 - carbon steel class 1500 3705 psig @ 100°F  
 255 bar + 38°C

For special execution see special features  
 For materials and testing pressure see technical data



## CLASS 800

FULL BORE - Type W 300									
SIZE	inch	1/4	3/8	1/2	3/4	1	1.1/4	1.1/2	2
	mm	6	10	15	20	25	32	40	50
A		80	80	90	110	127	150	180	210
B open		166	166	171	213	247	258	300	375
C		88	88	88	97	138	138	172	172
F		7	9	13	17,5	22,5	29,5	35	45
G		32	32	38	48	56	64	78	85
WEIGHT kg ≅		1,7	1,8	2	3	5	6,8	11	16,5
FIGURE		W 301	W 302	W 303	W 304	W 305	W 306	W 307	W 308
PACKING		BH3	BH3	BH3	BH5	BY5/A	BY5/A	BY7	BH8

REDUCED BORE - Type WL 300						
SIZE	inch	1/2	3/4	1	1.1/2	2
	mm	15	20	25	40	50
A		80	90	110	150	180
B open		166	171	213	258	300
C		88	88	97	138	172
F		9	13	17,5	29,5	35
G		32	38	48	64	78
WEIGHT kg ≅		1,7	2	3	6,6	10,4
FIGURE		WL 303	WL 304	WL 305	WL 307	WL 308
PACKING		BH3	BH3	BH5	BY5/A	BY7

## CLASS 1500

FULL BORE - Type 9W 300									
SIZE	inch	1/4	3/8	1/2	3/4	1	1.1/4	1.1/2	2
	mm	6	10	15	20	25	32	40	50
A		90	90	110	127	150	180	210	230
B open		166	166	210	247	256	300	375	428
C		88	88	97	138	138	172	172	234
F		7	9	12	15	20	27	32	40
G		38	38	48	56	64	78	85	95
WEIGHT kg ≅		2,2	2,2	3,5	5,5	7,6	10	20	30
FIGURE		9W 301	9W 302	9W 303	9W 304	9W 305	9W 306	9W 307	9W 308
PACKING		BH3	BH3	BH5	2B4/A	2B4/A	2B5	BH8	2B8/A

REDUCED BORE - Type 9WL 300						
SIZE	inch	1/2	3/4	1	1.1/2	2
	mm	15	20	25	40	50
A		90	110	127	180	210
B open		166	210	247	300	375
C		88	97	138	172	172
F		9	12	15	27	32
G		38	48	56	78	85
WEIGHT kg ≅		2	3,5	5,5	12	19
FIGURE		9WL 303	9WL 304	9WL 305	9WL 307	9WL 308
PACKING		BH3	BH5	2B4/A	2B5	BH8

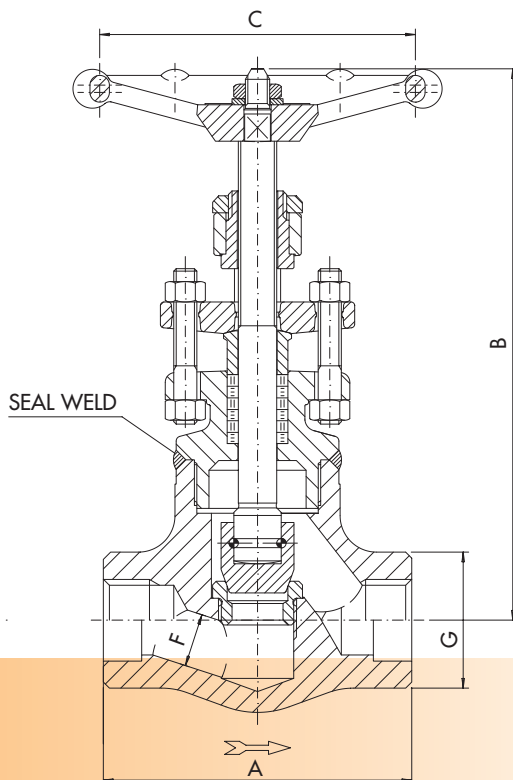

## GLOBE VALVES

