

## SXCS-6 Type Closed Coupled Industrial Coupling

The SXCS Type is the standard 6 bolt coupling with two hubs, two mounting rings, two disc packs and a split spacer designed for ease of installation and maintenance. Custom spacer lengths can be specified for special applications. The coupling has two flex planes (one at each disc pack) allowing it to accommodate parallel misalignment by the angular misalignment in each disc pack. This configuration will also accommodate axial misalignment within the specified limits.

### Features

- Unitized disc pack
- Infinite life when properly sized and aligned
- Torsionally rigid without any back lash
- No need for lubrication or maintenance
- No wearing parts and high resistance to harsh environmental conditions
- Disc packs can be replaced without moving equipment
- For larger sizes, refer to SXCST couplings, see Page D-20

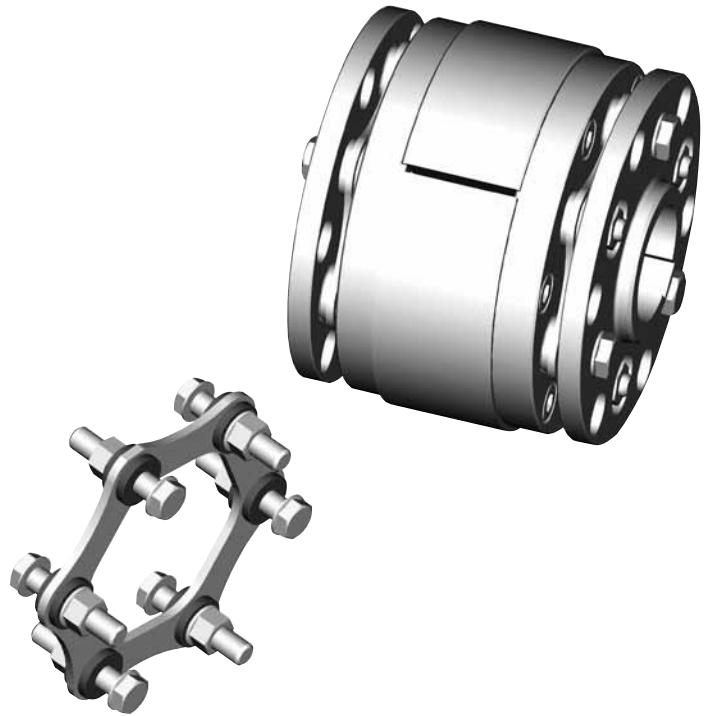

### SXCS-6 Performance Data

Size	Nominal Torque		Peak Torque		Max Speed		ID1 - ID2 Max Bore <sup>3</sup>		Weight <sup>4</sup>		Axial <sup>5</sup> Misalignment ± Δ Ka		Angular <sup>6</sup> Misalignment Max Degrees
	in-lbs	Nm	in-lbs	Nm	Unbal <sup>1</sup> RPM	Bal <sup>2</sup> RPM	in	mm	lbs	kg	in	mm	
110-6	5,100	575	10,200	1 150	7,200	18,000	1.56	40	16.5	7.5	0.083	2.1	1.5°
132-6	9,700	1 100	19,500	2 200	5,840	14,600	2.06	52	24.3	11.0	0.102	2.6	
158-6	17,700	2 000	35,400	4 000	4,920	12,300	2.38	60	41.9	19.0	0.122	3.1	
185-6	29,200	3 300	58,400	6 600	4,200	10,500	2.68	68	64.0	29.0	0.146	3.7	
202-6	40,700	4 600	81,400	9 200	3,840	9,600	3.06	78	84.0	38.0	0.150	3.8	1°
228-6	62,000	7 000	123,900	14 000	3,400	8,500	3.44	87	126.0	57.0	0.165	4.2	
255-6	90,300	10 200	180,600	20 400	3,080	7,700	3.88	99	185.0	84.0	0.185	4.7	
278-6	125,700	14 200	251,400	28 400	2,800	7,000	4.25	108	230.0	104.0	0.205	5.2	
302-6	177,000	20 000	354,000	40 000	2,560	6,400	4.63	118	306.0	139.0	0.224	5.7	

- Notes:
- 1 indicates: Operating speed must be equal or less than permissible speed which is limited by the weight and critical speed of the spacer.
  - 2 indicates: Couplings as manufactured can accommodate maximum speeds as listed. Higher speeds up to the value shown as 'Bal' require special balancing.
  - 3 indicates: The maximum bores shown are for cylindrical or taper shafts with keys. For other type of connections contact Lovejoy Technical Support.
  - 4 indicates: Weight is given for a complete coupling with minimum BSE and maximum bores.
  - 5 indicates: Axial misalignment is given for two disc packs.
  - 6 indicates: Angular misalignment is given for one disc pack.

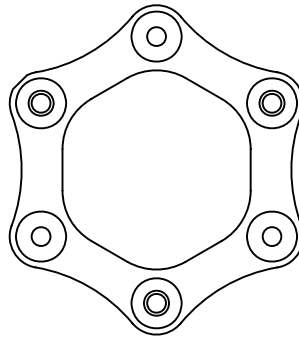
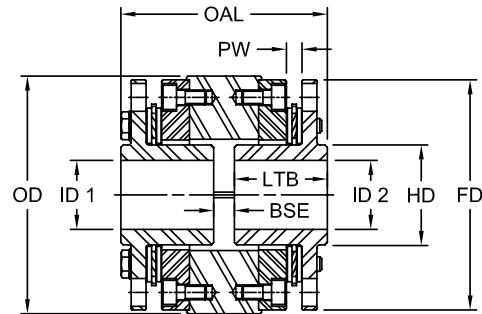
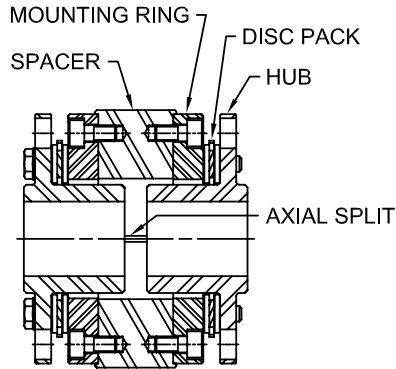

**SXCS-6 Dimensional Data**

Size	OAL <sup>8</sup>		PW		LTB		ID1 - ID2 Max Bore <sup>3</sup>		BSE <sup>7</sup> Standard		FD		HD		OD	
	in	mm	in	mm	in	mm	in	mm	in	mm	in	mm	in	mm	in	mm
110-6	4.38	111.3	0.331	8.4	1.97	50	1.56	40	0.44	11.2	4.88	124.0	2.13	54	5.04	128.0
132-6	5.08	129.0	0.331	8.4	2.36	60	2.06	52	0.36	9.1	5.71	145.0	2.79	71	5.87	149.1
158-6	5.99	152.1	0.441	11.2	2.76	70	2.38	60	0.47	11.9	6.73	170.9	3.31	84	6.89	175.0
185-6	6.88	174.8	0.551	14.0	3.15	80	2.68	68	0.58	14.7	7.68	195.1	3.74	95	7.83	198.9
202-6	7.72	196.1	0.610	15.5	3.54	90	3.06	78	0.64	16.3	8.43	214.1	4.25	108	8.58	217.9
228-6	8.60	218.4	0.689	17.5	3.94	100	3.44	87	0.72	18.3	9.57	243.1	4.84	123	9.72	246.9
255-6	10.27	260.9	0.807	20.5	4.53	115	3.88	99	1.21	30.7	10.79	274.1	5.43	138	10.94	277.9
278-6	10.71	272.0	0.835	21.2	4.92	125	4.25	108	0.87	22.1	11.58	294.1	5.99	152	11.73	297.9
302-6	11.72	297.7	0.961	24.4	5.32	135	4.63	118	1.08	27.4	12.88	327.2	6.50	165	13.03	331.0

- Notes:
- 3 indicates: The maximum bores shown are for cylindrical or taper shafts with keys. For splines and other types of bores, contact Lovejoy Technical Support.
  - 7 indicates: BSE is the distance between shaft ends and is a variable parameter.
  - 8 indicates: OAL is measured from the end of the hubs and does not include the bolt heads.
  - Customer is responsible for ensuring there is enough room between the coupling and equipment to install the bolts and properly torque them with a torque wrench. Additional shaft length may be required. See Disc Coupling Worksheet, page D-8 item 5.