

Roquet



LEHENGOTAK, S.A.

- Bombas LO

CATÁLOGO

Nuestras bombas están equilibradas hidrostáticamente y provistas de reajuste lateral automático.

- Se recomienda el empleo de aceite para instalaciones oleodinámicas con aditivos antiespumantes y de extrema presión.
- Para obtener una larga vida, tanto del aceite como de la bomba es preciso trabajar entre una viscosidad de 20-80 cSt, según presiones de trabajo a una temperatura de 50° C.
- Gama de temperaturas del fluido hidráulico -20° C + 80° C.
- El apartado de filtraje es muy importante, ya que la mayoría de averías son debidas a la suciedad del aceite.
- Recomendamos: filtraje en aspiración 125 µ mínimo.
- Filtraje en retorno 25 µ mínimo.
- La mejor forma de accionamiento es de conexión directa por medio de un acoplamiento elástico, que permite un movimiento mínimo radial y axial de 0,3 a 0,4 mm, por lo que de esta forma quedarán absorbidas todas las vibraciones del motor que tanto perjudican la buena marcha de la bomba.
- Los conductos de aspiración serán lo suficientemente dimensionados para que la depresión no exceda de 0,3 bars.
- Conexión por bridas o rosca B.S.P.
- Sentido de giro derecha o izquierda, mirando la bomba por el lado del eje.
- Antes de poner por primera vez la bomba en marcha. asegurarse que el sentido de giro es el correcto.
- Algunas referencias están sujetas a cantidades mínimas.

Our pumps are hydrostatically balanced and have automatic lateral adjustment.

- We recommend the use of hydraulic fluid with antifoaming additives and for extreme pressure.*
- To obtain extended pump life it is necessary to work with oil viscosities between 20-80 cSt, relating to working pressure and at a temperature of 50° C.*
- Oil temperature range -20° C - + 80°C.*
- Filtration is extremely important since most problems are due to oil contamination.*
- Filtration recommended in suction line: 125 µ minimum.*
- Filtration recommended in return line: 25 µ minimum.*
- The most efficient drive method is by means of axial flexible coupling, with minimum 0,3 - 0,4 mm. radial and axial movement, thus reducing the effects of vibration and maintaining maximum efficiency of the pump.*
- The suction pipes should be large enough to ensure that cavitation does not exceed 0,3 bar.*
- Connection by side flange, or threaded B.S.P.*
- Rotation direction: Clockwise or anti-clockwise when facing the shaft end.*
- Before starting the pump, make sure the direction of rotation is correct.*
- Double and multiple pumps are available with the mounting details shown for single pumps.*
- Some types subject to minium batch quantities.*

Índice

Index

Nomenclatura de referencias	04	<i>Part numbers</i>	04
Datos técnicos hidráulicos	05	<i>Hydraulic technical data</i>	05
Datos técnicos	05	<i>Technical data</i>	05
Bombas simples	06	<i>Single pump</i>	06
Tapa tipo 01	06	<i>Front flange type 01</i>	06
Tapa tipo 09	07	<i>Front flange type 09</i>	07
Tapa tipo 10	08	<i>Front flange type 10</i>	08
Tapa tipo 22	09	<i>Front flange type 22</i>	09
Tapa tipo 27	10	<i>Front flange type 27</i>	10
Ejemplo para pedidos de recambios	11	<i>Example to order spare parts</i>	11
Bombas dobles de engranajes serie LQ	12	<i>Double gear pumps type LQ</i>	12
Tapa tipo 10	12	<i>Front flange type 10</i>	12
Ejemplo para pedidos de recambios	13	<i>Example to order spare parts</i>	13
Bombas dobles de engranajes serie LP	14	<i>Double gear pumps type LP</i>	14
Tapa tipo 10	14	<i>Front flange type 10</i>	14
Ejemplo para pedidos de recambios	15	<i>Example to order spare parts</i>	15
Con conexión tomas solo T	16	<i>Side port connection form T only</i>	16
Con conexión tomas solo R	17	<i>Side port connection form R only</i>	17
Diferentes tipos de polea	17	<i>Varius types of pulley</i>	17

Este catálogo muestra el producto en su configuración más estándar; diseños especiales son posibles, por favor contacte con PEDRO ROQUET, S.A. Las especificaciones y datos en este catálogo no están abiertos a ninguna interpretación, por favor contacte con PEDRO ROQUET, S.A. en caso de duda. PEDRO ROQUET, S.A. se reserva el derecho de modificar, actualizar o revisar este catálogo sin notificar previamente. PEDRO ROQUET, S.A. NO ES RESPONSABLE DE NINGÚN DAÑO CAUSADO POR UN USO INCORRECTO DEL PRODUCTO.

This Catalogue shows the product in the most standard configuration; customized or special designs are also available, please contact to PEDRO ROQUET, S.A. The specifications and data in this catalogue are not open to any interpretation, please contact with PEDRO ROQUET, S.A. in case of doubt.

PEDRO ROQUET, S.A. reserves the right to modify, update or revise this catalogue without prior notice.

PEDRO ROQUET, S.A. IS NOT RESPONSIBLE FOR ANY DAMAGE CAUSED BY INCORRECT USE OF THE PRODUCT.

Nomenclatura de referencias Coding systems



NOMENCLATURA DE REFERENCIA

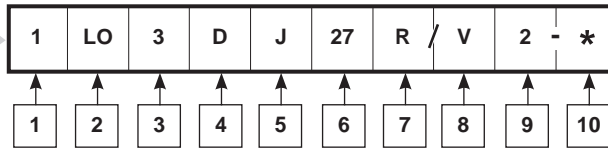

CODING SYSTEM

1	Tipo Type
1	Sin polea - <i>Without pulley</i>
2	Con polea - <i>With pulley</i>

2	Modelo Model
LO	Simple - <i>Single</i>
LQ	Múltiple - <i>Multiple banked / L0+L0</i>
LP	Múltiple - <i>Multiple banked / L0+M</i>

3	Caudal bomba a 1500 RPM a 0 bar <i>Pump flow rate at 1500 RPM at 0 bar</i>
Ver hoja técnica <i>See technical data</i>	

4	Sentido giro Rotation
D	Derecha - <i>Clockwise</i>
I	Izquierda - <i>Counterclockwise</i>
R	Reversible - <i>Reversible</i>

5	Forma eje motriz <i>Driving shaft form</i>
B - C - E - J - Z - H	

5	Tipo polea <i>Pulley type</i>
P - R	

6	Tipo tapa <i>Fixing flange</i>
01 - 09 - 10 - 22 - 27	

7	Formas conexión tomas <i>Port connection form</i>
<div style="display: flex; justify-content: space-around;"> T R F </div>	

8	Variantes con válvulas <i>Alternatives with valves</i>
V	Válvula limitadora - <i>Relief valve</i>
VA	Válvula antirretorno - <i>Check valve</i>

9	Presión de taraje <i>Pressure setting</i>
11	5 - 80 bar
12	80 - 175 bar
13	175 - 250 bar

10	Datos adicionales <i>Additional data</i>
----	--

NOTA: Medidas en mm. si no se indica lo contrario.

NOTE: Measurements in mm. unless otherwise indicated.

Para bombas reversibles las conexiones serán iguales en ambos lados y las medidas corresponderán a la toma de aspiración.
In reversible pumps, side ports are both the same as the single pump suction port.

Los dibujos representados indican que la bomba es de giro derecha, para giro izquierda se sustituirá la "D" de la referencia por una "I", en este caso los orificios de aspiración y presión estarán invertidos.

The drawings show pumps turning clockwise. For anti-clockwise rotation, replace "D" by "I", in which case suction and pressure ports shall be inverted.

PEDRO ROQUET, S.A. se reserva el derecho a exigir unas cantidades mínimas en pedidos. Para piezas de recambio se debe conocer exactamente la referencia de la bomba y la serie.

PEDRO ROQUET, S.A. reserves the right to demand minimum quantities. The exact pump reference and series must be provided for spare parts orders.

Datos técnicos hidráulicos Hydraulic technical data



Datos técnicos Technical data						
Caudal bomba <i>Pump Flow rate</i>	(L/mín.) 1500 R.P.M.	1,5	3	5	7,5	10
Cilindrada <i>Displacement</i>	cm ³ /v cc/r	1	2	3,3	5	6,6
Presión máx. continuada en <i>Cont. max. pressure</i>	bar	275		240	185	135
Presión máx. inter 5 seg. máx. <i>Intermittent max. pressure</i>	bar	300		275	200	150
R.P.M. a presión continua <i>R.P.M. at cont. pressure</i>		5.000		4.000	3.000	
R.P.M. máximas <i>Max. R.P.M.</i>		6.000		5.000	4.000	3.000
Mínimas R.P.M. según presión <i>Min. R.P.M. at given pressures</i>	100 bar	1.000		750	500	
	175 bar	1.500	1.250		1.000	—
	250 bar	2.000	1.750	1.500	—	—
	300 bar	3.000	2.000	—	—	—
Aceite recomendado <i>Fluid to be used</i>		ISO 6743 tipo HM, HV ó HG				
Viscosidad <i>Viscosity range</i>		ISO 3448 cat. VG32-VG46				
Grado de limpieza del aceite <i>Recommended fluid cleanliness</i>		19/16 s/. ISO 4406 ó RP70H				
Temperatura de trabajo <i>Working temperature</i>		-20°C... +80°C -70°F... +175°F				
Depresión máximo en aspiración <i>Max. suction depression</i>		< 0'3 bar				

CONEXIONES TIPO T Y R

PEDRO ROQUET S.A. recomienda utilizar implantaciones roscadas cilíndricas: con cierre por arista de estanqueidad, junta plana o junta tórica. (Ver normas: DIN 3852, ISO1179, ISO 9974 y ISO 6149). No se recomienda utilizar otras implantaciones tipo cónicas, etc. A continuación se detallan los pares de apriete para implantaciones roscadas cilíndricas.

CONNECTION TYPES T AND R

PEDRO ROQUET S.A. recommends to use threaded fittings with parallel threads: with sealing face, with flat seal or with o-ring seal (Standards: DIN 3852, ISO1179, ISO 9974 y ISO6149). It is not recommended to use conic type fittings, etc. Guide for tightening torques for threaded fittings with parallel threads:

PAR DE APRIETE / ASSEMBLY TORQUE

Rosca (ISO 228-1) <i>Thread Size (ISO 228-1)</i>	Par de apriete min. (Nm) <i>Assembly Torque min. (Nm)</i>	Par de apriete máx. (Nm) <i>Assembly Torque max. (Nm)</i>
1/8 " BSP	20	25
1/4 " BSP	50	55
3/8 " BSP	80	90
1/2 " BSP	100	100
3/4 " BSP	200	220
1 " BSP	380	420

ACCIONAMIENTO DE LAS BOMBAS:

Deben utilizarse acoplamientos entre bomba y accionamiento que eviten la transmisión de esfuerzos tanto axiales como laterales. Las bombas en su configuración estandar no admiten este tipo de esfuerzos, causando una disminución rápida de su vida útil.

PUMP DRIVING DEVICES:

It must be used a driving device to avoid the transmission of axial and radial loads to the axis of the pump. Standard flanges and pumps are not designed to handle this loads and this causes a reduction of its working life.



Diagrama de rendimientos volumétricos a 1500 R.P.M.
Volumetric efficiencies diagram at 1500 R.P.M.



Diagrama de caudales y potencias
Flow rate and power diagram



NOTA: Estos diagramas han sido obtenidos con un aceite de 5° E (37 cSt) de viscosidad y una temperatura de 50° C.
NOTE: These results have been obtained with 5° E (37 cSt) viscosity oil and at 50° deg C.

6 Tapa tipo 01
Front flange type

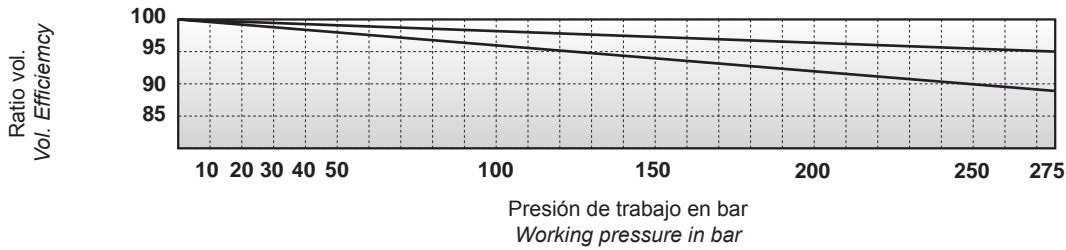
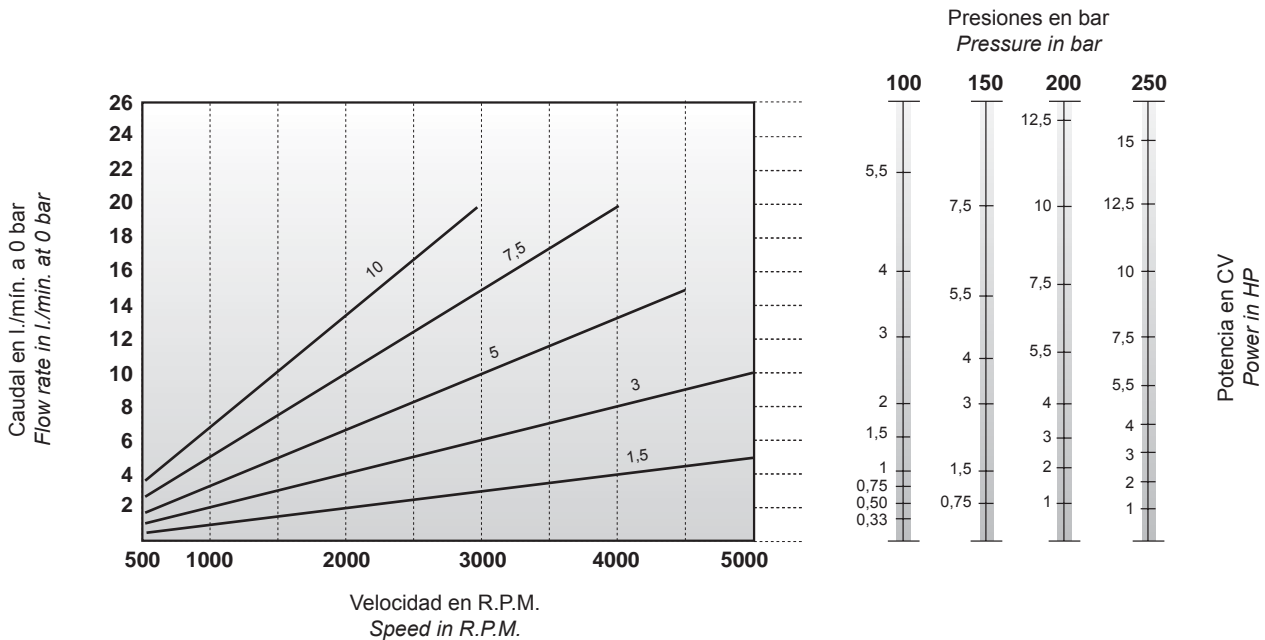
5 Eje forma C
Shaft form

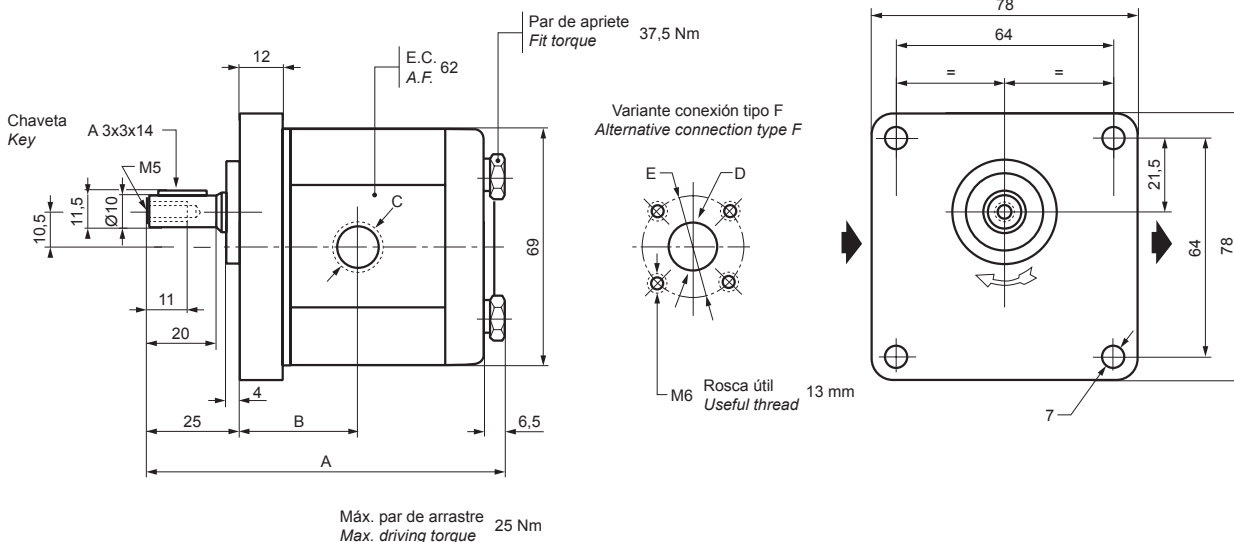

5 Eje forma B
Shaft form

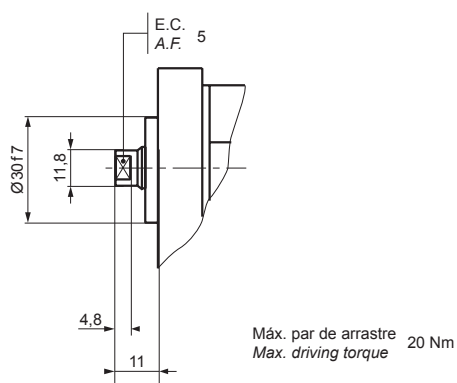

Modelo Model	Cilindrada cm³/v Displacement cc/r	A	B	Presión / Pressure			Aspiración / Suction			Peso kg Weight kg
				C	D	E	C	D	E	
1L01,5D▲01R	1	92,8	31	1/4" BSP	11	30	3/8" BSP	14	30	1,350
1L03D▲01R	2	97,8								1,436
1L05D▲01R	3,3	104,8	34,5	3/8" BSP	11	30	1/2" BSP	14	30	1,518
1L07,5D▲01R	5	113,25	37,5							1,640
1L010D▲01R	6,6	121,8	42,8							1,766

▲ Forma eje / Shaft form

6 Tapa tipo 09
Front flange type

5 Eje forma H
Shaft form

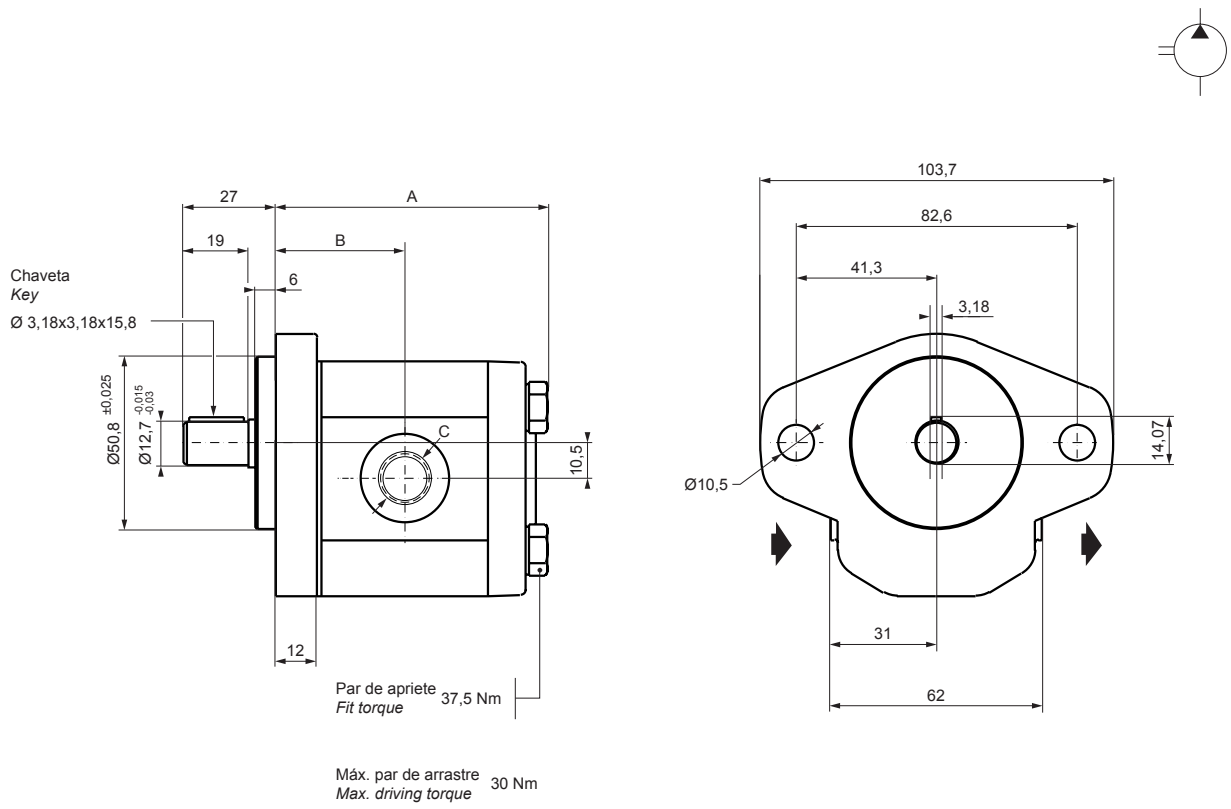

Modelo Model	Cilindrada cm³/v Displacement cc/r	A	B	Presión / Pressure	Aspiración / Suction	Peso kg Weight kg
				C	C	
1L01,5DH09S	1	96,3	32	9/16"-18 UNF O ring	3/4"-16 UNF O ring	1,378
1L03DH09S	2	101,3	35			1,464
1L05DH09S	3,3	108,3	38			1,546
1L07,5DH09S	5	116,75	42			1,664
1L010DH09S	6,6	125,3	48			1,790

6 **Tapa tipo** 10
Front flange type

5 **Eje forma** E
Shaft form

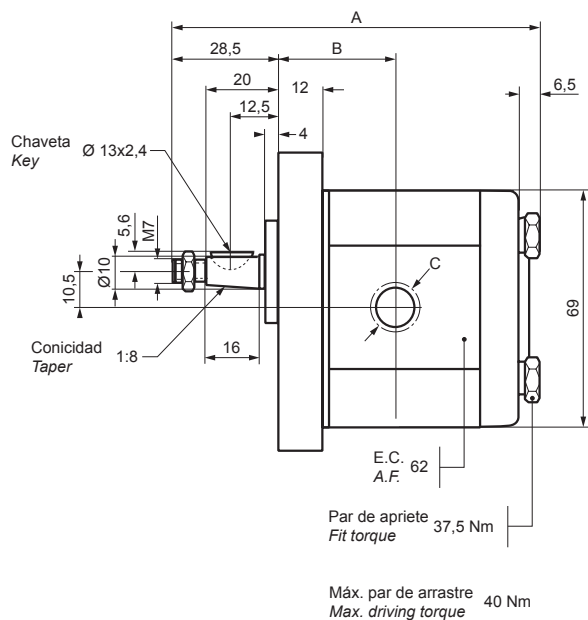

Variante conexión tipo F
Alternative connection type F

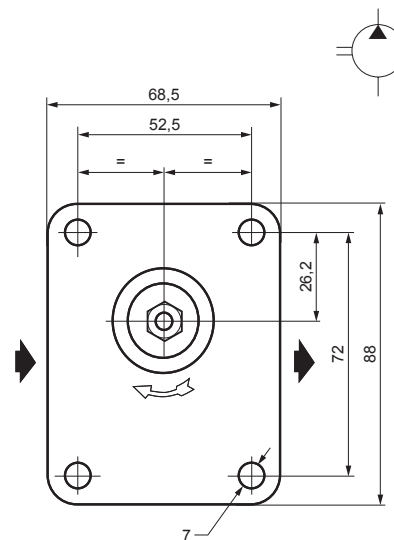
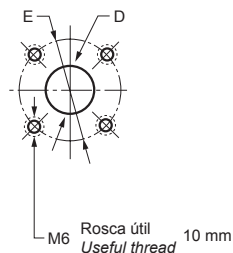

5 **Eje forma** C
Shaft form

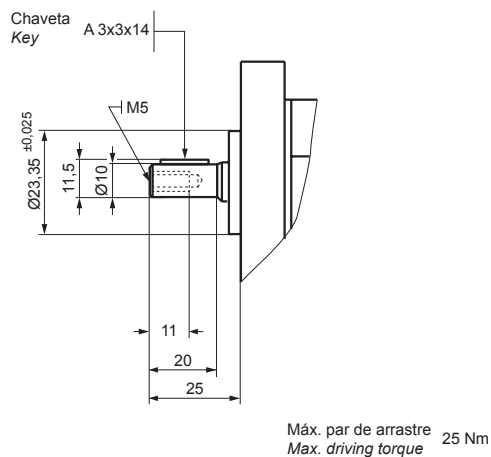

Modelo Model	Cilindrada cm ³ /v Displacement cc/r	A	B	Presión / Pressure			Aspiración / Suction			Peso kg Weight kg
				C	D	E	C	D	E	
1L01,5D▲10R	1	96,3	31	1/4" BSP	11	30	3/8" BSP	14	30	1,378
1L03D▲10R	2	101,3								1,464
1L05D▲10R	3,3	108,3	34,5	3/8" BSP	11	30	1/2" BSP	14	30	1,546
1L07,5D▲10R	5	116,75	37,5							1,664
1L010D▲10R	6,6	125,3	42,8							1,790

▲ Forma eje / Shaft form

6 Tapa tipo 22
Front flange type

5 Eje forma J
Shaft form

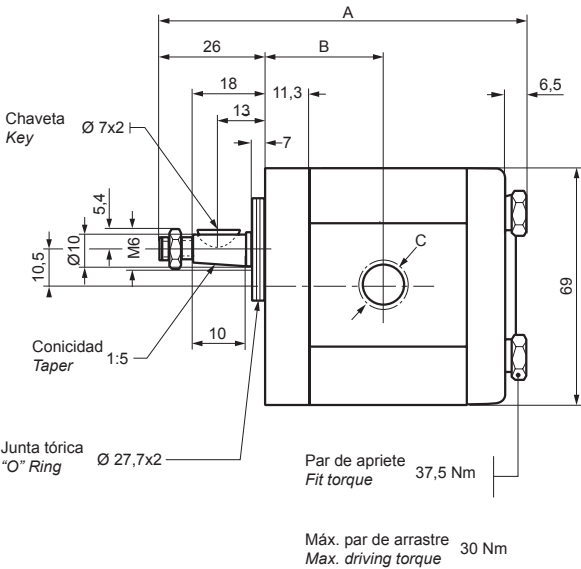

Variante conexión tipo F
Alternative connection type F

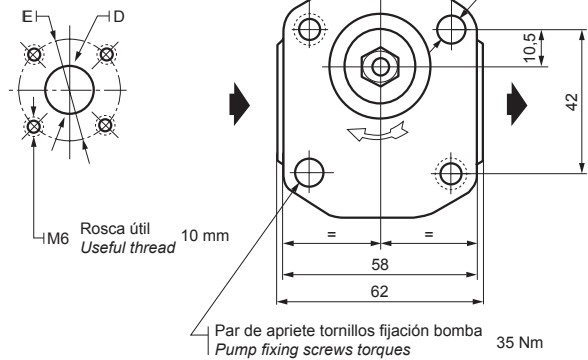

5 Eje forma B
Shaft form

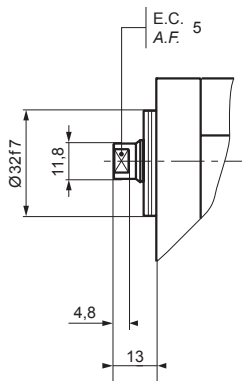

Máx. par de arrastre 20 Nm
Max. driving torque



Modelo Model	Cilindrada cm ³ /v Displacement cc/r	A	B	Presión / Pressure			Aspiración / Suction			Peso kg Weight kg
				C	D	E	C	D	E	
1L01,5D▲22R	1	91,8	29	1/4" BSP	11	30	3/8" BSP	14	30	1,040
1L03D▲22R	2	96,8								1,126
1L05D▲22R	3,3	103,8	32,5	3/8" BSP	11	30	1/2" BSP	14	30	1,208
1L07,5D▲22R	5	112,25	35,5							1,326
1L010D▲22R	6,6	120,8	40,8							1,452

▲ Forma eje / Shaft form

6 Tapa tipo 27
Front flange type

5 Eje forma Z
Shaft form

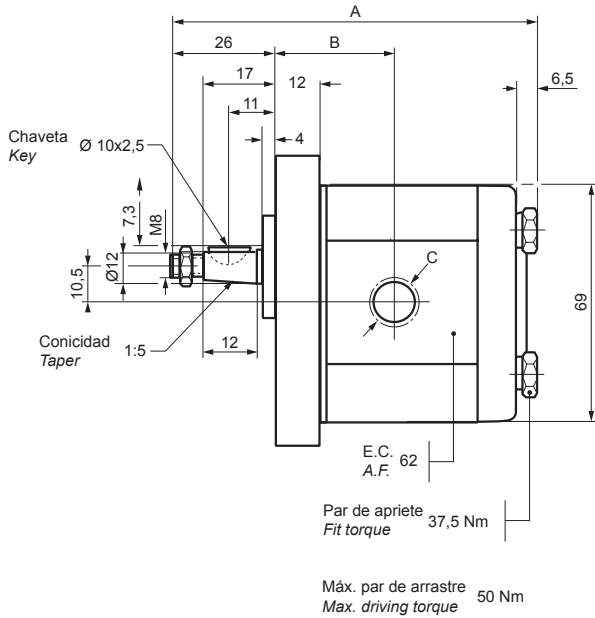

Variante conexión tipo F
Alternative connection type F

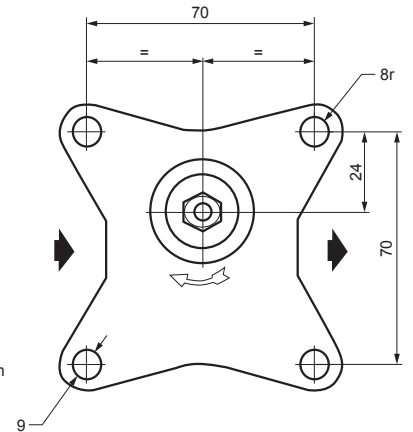
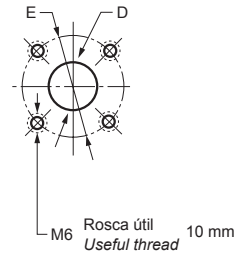

5 Eje forma C
Shaft form

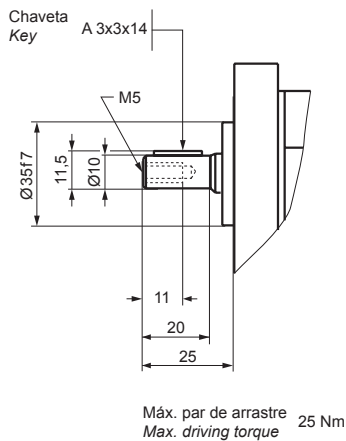

5 Eje forma B
Shaft form

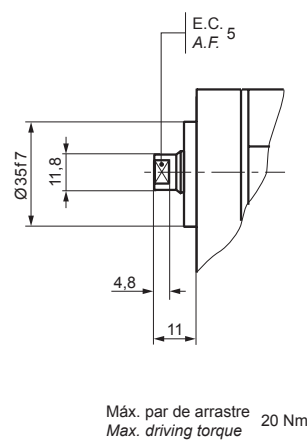

Modelo Model	Cilindrada cm ³ /v Displacement cc/v	A	B	Presión / Pressure			Aspiración / Suction			Peso kg Weight kg
				C	D	E	C	D	E	
1L01,5D▲27R	1	93,8	31	1/4" BSP	11	30	3/8" BSP	14	30	1,195
1L03D▲27R	2	98,8								1,281
1L05D▲27R	3,3	105,8	34,5	3/8" BSP	11	30	1/2" BSP	14	30	1,363
1L07,5D▲27R	5	114,25	37,5							1,481
1L010D▲27R	6,6	122,8	42,8							1,607

▲ Forma eje / Shaft form

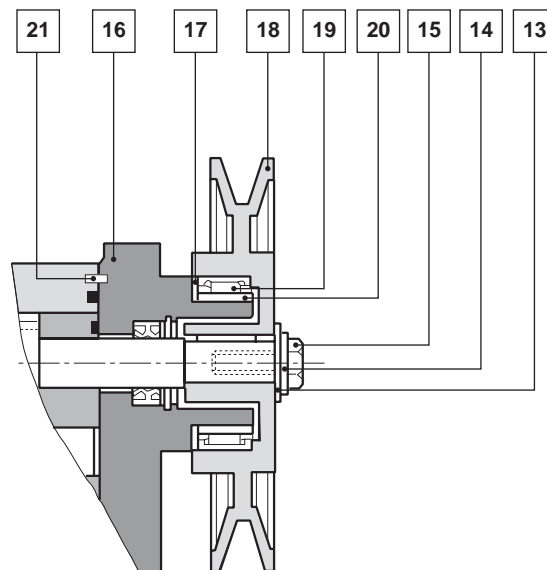
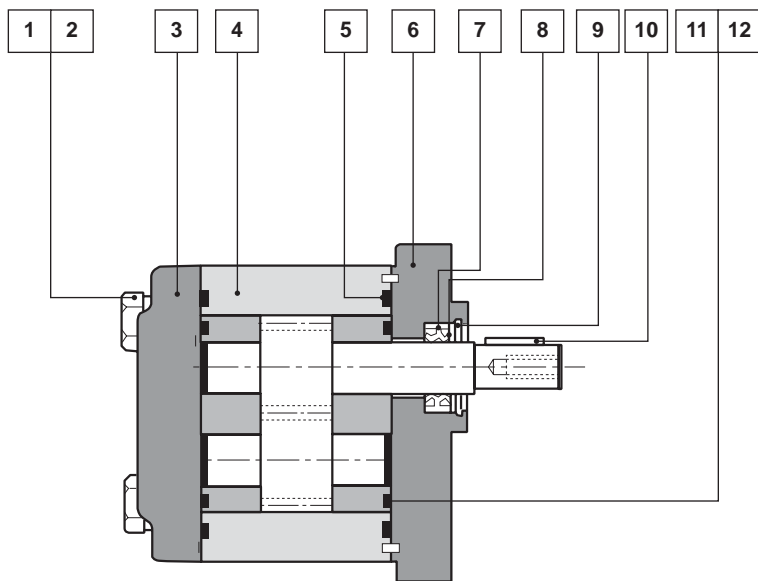

El conjunto marca 4 está compuesto por:

- 1.- Cuerpo bomba
- 2.- Cojinetes
- 1.- Rueda dentada motriz
- 1.- Rueda dentada conducida

The set mark 4 consist of:

- 1.- Pump housing
- 2.- Bearings
- 1.- Driving gear
- 1.- Driven gear

Cantidad Quantity	Denominación Description	Nº de la pieza Part number	Referencia según la placa Ref. according serial number plate
1	Chaveta Key	10	Para bomba For pump 1L05DC01F

Nº	Denominación Description	Cantidad Quantity
1	Tornillos Screw M8	4
2	Arandelas Washer Ø8 DIN-6797	4
3	Tapa posterior Back cover	1
4	Conjunto cuerpo bomba Pump housing sub-assembly	1
5	Juntas de tope Body seal	2
6	Tapa y soporte bomba Flange	1
7	Retén aceite doble Shaft seal	1
8	Junta guía Guide washer	1
9	Anillo elástico Circlip	1
10	Chaveta Key	1
11	Junta de compensación Compensation seal	2

Nº	Denominación Description	Cantidad Quantity
12	Junta antiextrusión Anti-extrusion seal	2
13	Arandela Washer	1
14	Fijador tuerca Safety washer	1
15	Tornillo Screw M5 x 15 DIN-933	1
16	Tapa tipo polea Flange	1
17	Arandela tope cojinete Washer	1
18	Polea Pulley	1
19	Cojinete de agujas Needle bearing	1
20	Anillo cojinete Bearing ring	1
21	Centrador Pin	2

El conjunto de juntas de recambios está compuesto los por números 5-7-11-12.
The spare seals Kit is composed of parts no. 5-7-11-12.

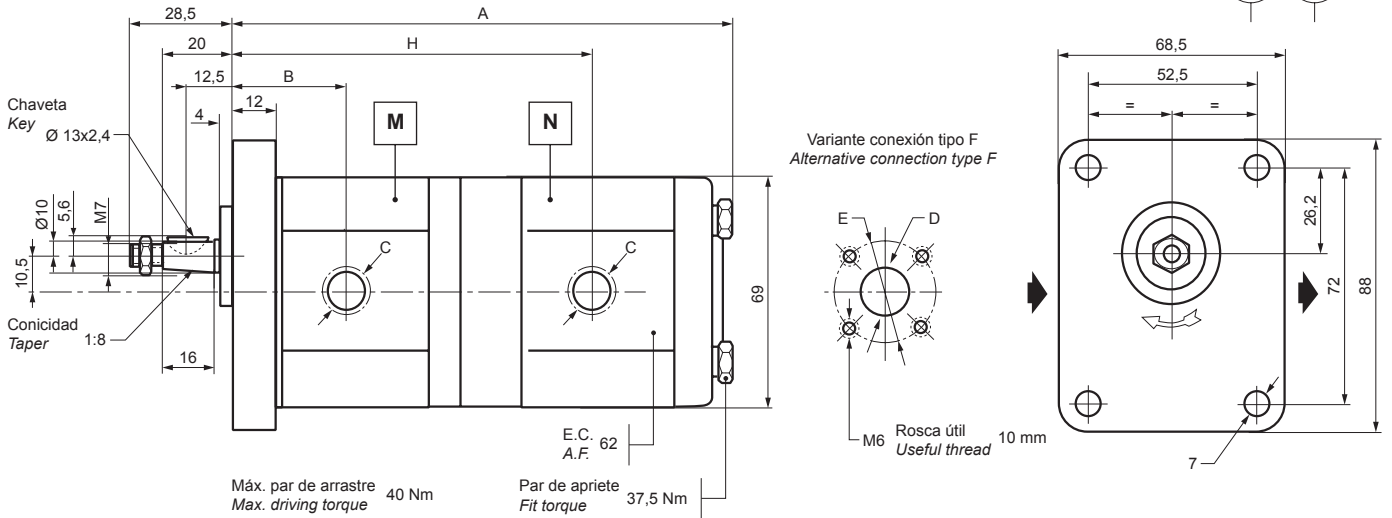
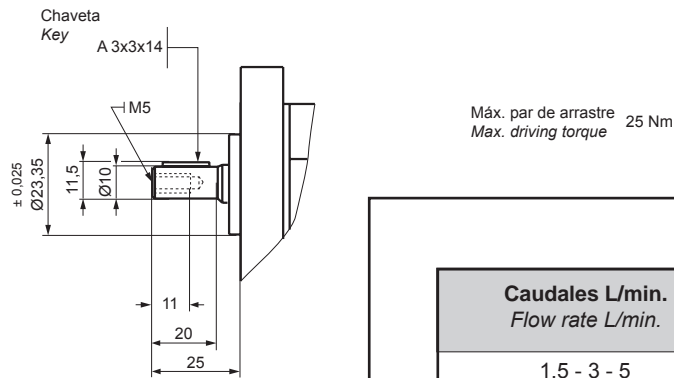
6 Tapa tipo 10
Front flange type
5 Eje forma E
Shaft form

5 Eje forma C
Shaft form

Caudales L/min. Flow rate L/min.	Presión Pressure			Aspiración Suction		
	C	D	E	C	D	E
1,5 - 3 - 5	1/4" BSP	11	30	3/8" BSP	14	30
7,5 - 10	3/8" BSP			1/2" BSP		

Modelo Model	Cilindrada cm ³ /v / Displacement cc/r		A	B	H	Peso kg Weight kg
	M	N				
1LQ1,5-1,5D▲10R	1	1	132,3	31	95,5	2,394
1LQ3-1,5D▲10R	2	1	137,3		100,5	2,480
1LQ3-3D▲10R		2	142,3		2,566	
1LQ5-1,5D▲10R	3,3	1	144,3	34,5	107,5	2,562
1LQ5-3D▲10R		2	149,3		2,648	
1LQ5-5D▲10R		3,3	156,3		2,730	
1LQ7,5-1,5D▲10R	5	1	152,75	37,5	116	2,680
1LQ7,5-3D▲10R		2	157,75		2,766	
1LQ7,5-5D▲10R		3,3	164,75		2,848	
1LQ7,5-7,5D▲10R		5	173,3		2,966	
1LQ10-1,5D▲10R	6,6	1	161,3	42,8	124,5	2,806
1LQ10-3D▲10R		2	166,3		2,892	
1LQ10-5D▲10R		3,3	173,3		2,974	
1LQ10-7,5D▲10R		5	181,75		3,092	
1LQ10-10D▲10R		6,6	190,3		3,218	

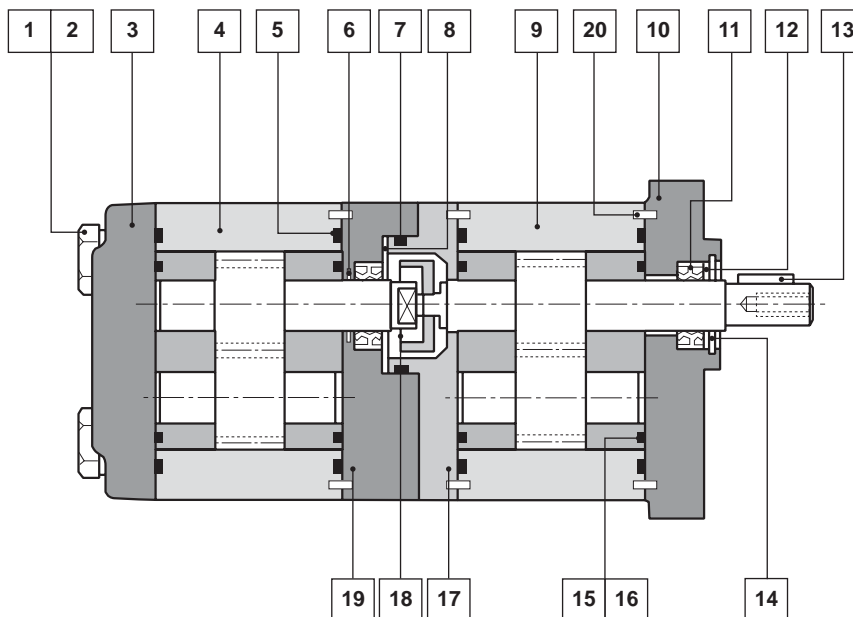
▲ Forma eje / Shaft form



Los conjuntos marcas 4-9 están compuestos por:

- 1.- Cuerpo bomba
- 2.- Cojinetes
- 1.- Rueda dentada motriz
- 1.- Rueda dentada conducida

Part numbers 4-9 consist of:

- 1.- Pump housing
- 2.- Bearings
- 1.- Driving gear
- 1.- Driven gear

Cantidad Quantity	Denominación Description	Nº de la pieza Part number	Referencia según la placa Ref. according serial number plate
2	Retén aceite doble Oil seal	13	Para bomba For pump 1LQ7,5-3DC10R

Nº	Denominación Description	Cantidad Quantity
1	Tornillos Screw M8	4
2	Arandelas Washer Ø8 DIN-6797	4
3	Tapa posterior Back cover	1
4	Conjunto cuerpo bomba Pump housing sub-assembly	1
5	Juntas de tope Body seal	2
6	Aro guía Guide ring	1
7	Junta tórica O ring	1
8	Arandela tope retén Oil-seal washer	1
9	Conjunto cuerpo bomba Pump housing sub-assembly	1
10	Tapa soporte bomba Flange	1

Nº	Denominación Description	Cantidad Quantity
11	Retén aceite doble Oil seal	2
12	Junta guía Guide washer	1
13	Chaveta Key	1
14	Anillo elástico Circlip M5 x 15 DIN-933	1
15	Juntas de compensación Compensation seal	4
16	Junta antiextrusión Anti-extrusion seal	4
17	Tapa bomba doble Double pump flange	1
18	Cruzeta Coupling	1
19	Tapa bomba doble (retén) Double pump flange (oil seal)	1
20	Centrador Pin	6

El conjunto de juntas de recambios está compuesto por los números 5-7-11-12.
 The spare seals Kit is composed of parts no. 5-7-11-12.

6 Tapa tipo 10
Front flange type

5 Eje forma E
Shaft form

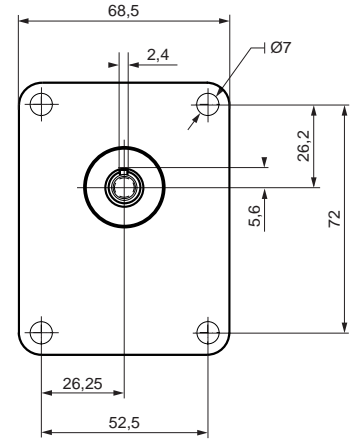
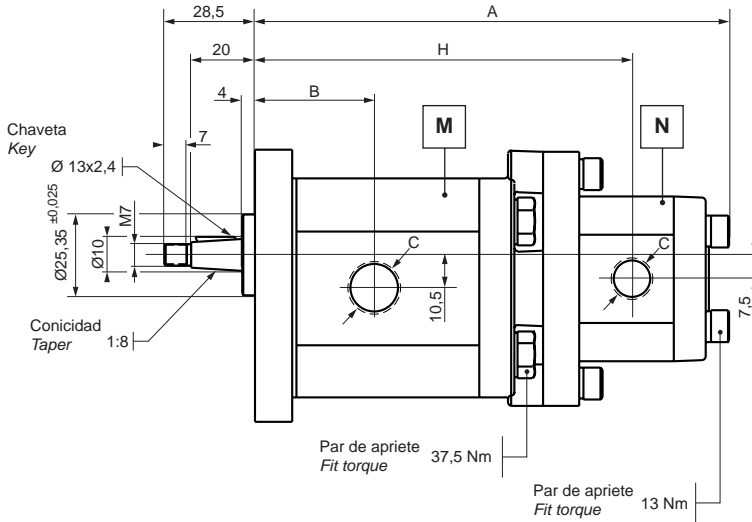
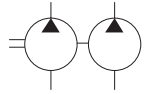

Máx. par de arrastre 40 Nm
Max. driving torque



Caudales L/min. Flow rate L/min.	Presión Pressure	Aspiración Suction
	C	C
1,5 - 3 - 5	1/4" BSP	3/8" BSP
7,5 - 10	3/8" BSP	1/2" BSP
Bomba N	1/4" BSP	1/4" BSP

Modelo Model	Cilindrada cm³/v Displacement cc/r		A	B	H	Peso kg Weight kg
	M	N				
1LP1,5-0,5DE10R	1	0,33	125,5	31	97	
1LP1,5-0,75DE10R		0,5	127,5		98	
1LP1,5-1DE10R		0,66	129,5		98,5	
1LP1,5-1,25DE10R		0,83	131,5		98,5	
1LP1,5-1,5DE10R		1	133,5		101	
1LP1,5-2DE10R		1,33	137,5		101	
1LP3-0,5DE10R		2	0,33		130,5	102
1LP3-0,75D10R	0,5		132,5	103		
1LP3-1D10R	0,66		134,5	103,5		
1LP3-1,25D10R	0,83		136,5	103,5		
1LP3-1,5D10R	1		138,5	106		
1LP3-2D10R	1,33		142,5	106		
1LP5-0,5DE10R	3,3		0,33	137,5	109	
1LP5-0,75D10R		0,5	139,5	110		
1LP5-1D10R		0,66	141,5	110,5		
1LP5-1,25D10R		0,83	143,5	110,5		
1LP5-1,5D10R		1	145,5	113		
1LP5-2D10R		1,33	149,5	113		

Modelo Model	Cilindrada cm³/v Displacement cc/r		A	B	H	Peso kg Weight kg
	M	N				
1LP7,5-0,5DE10R	5	0,33	146	37,5	117,5	
1LP7,5-0,75D10R		0,5	148		118,5	
1LP7,5-1D10R		0,66	150		119	
1LP7,5-1,25D10R		0,83	152		119	
1LP7,5-1,5D10R		1	154		121,5	
1LP7,5-2D10R		1,33	158		121,5	
1LP10-0,5DE10R		6,6	0,33		154,5	42,8
1LP10-0,75D10R	0,5		156,5	127		
1LP10-1D10R	0,66		158,5	127,5		
1LP10-1,25D10R	0,83		160,5	127,5		
1LP10-1,5D10R	1		162,5	130		
1LP10-2D10R	1,33		167	130		

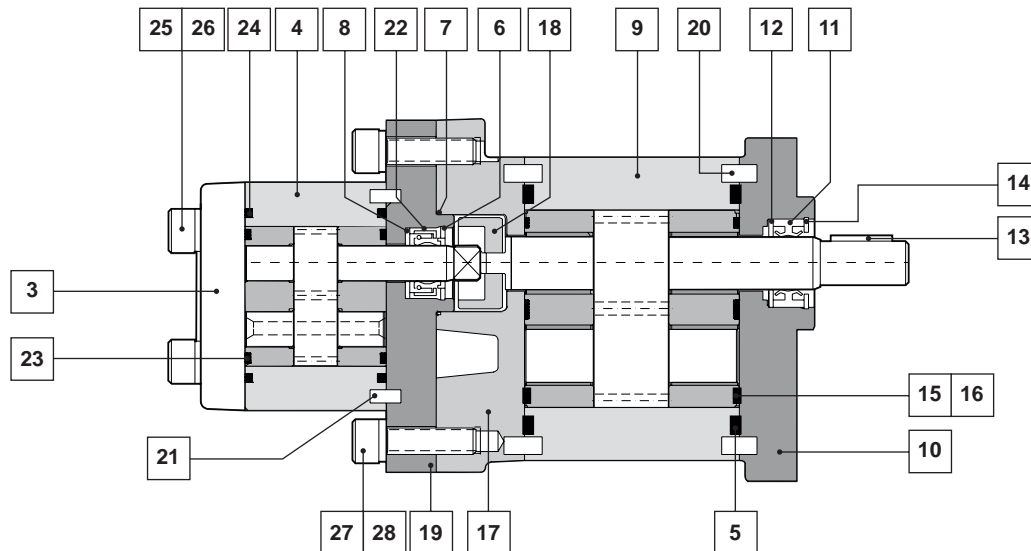

Los conjuntos marcados 4-9 están compuestos por:

- 1.- Cuerpo bomba
- 2.- Cojinetes
- 1.- Rueda dentada motriz
- 1.- Rueda dentada conducida

Part numbers 4-9 consist of:

- 1.- Pump housing
- 2.- Bearings
- 1.- Driving gear
- 1.- Driven gear

Cantidad Quantity	Denominación Description	Nº de la pieza Part number	Referencia según la placa Ref. according serial number plate
1	Retén aceite doble Oil seal	13	Para bomba For pump 1LP3-1DC10R

Nº	Denominación Description	Cantidad Quantity
1	Tornillos Screw M8 DIN-931	4
2	Arandelas Washer Ø8 DIN-6797	4
3	Tapa posterior Back cover	1
4	Conjunto cuerpo bomba Pump housing sub-assembly	1
5	Juntas de tope Body seal	2
6	Anillo elástico Circlip Ø6 DIN-472	1
7	Junta tórica O ring	1
8	Arandela tope retén Oil-seal washer	1
9	Conjunto cuerpo bomba Pump housing sub-assembly	1
10	Tapa soporte bomba Flange	1
11	Retén aceite doble Shaft seal	1
12	Junta guía Guide washer	1
13	Chaveta Key	1
14	Anillo elástico Circlip Ø22 DIN-472	1

Nº	Denominación Description	Cantidad Quantity
15	Juntas de compensación Compensation seal	4
16	Junta antiextrusión Anti-extrusion seal	4
17	Tapa bomba doble Double pump flange	1
18	Cruzeta Coupling	1
19	Tapa bomba doble (retén) Double pump flange (oil seal)	1
20	Centrador Pin	4
21	Centrador Pin	2
22	Retén aceite Oil seal	1
23	Juntas de compensación Compensation seal	2
24	Juntas de tope Body seal	2
25	Tornillos Screw M6 DIN-912	4
26	Arandelas Washer Ø6 DIN-6797	4
27	Tornillos Screw M6 DIN-912	2
28	Arandelas Washer Ø6 DIN-6797	2

El conjunto de juntas de recambios está compuesto por números 5-7-11-15-16-22-23-24.
The spare seals Kit is composed of parts no. 5-7-11-15-16-22-23-24.

7 Con conexión tomas solo T
Side port connection form T only

Tapa posterior para bombas con tomas traseras
Back cover with rear ports

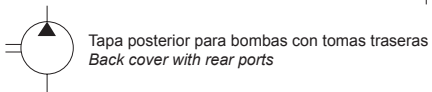
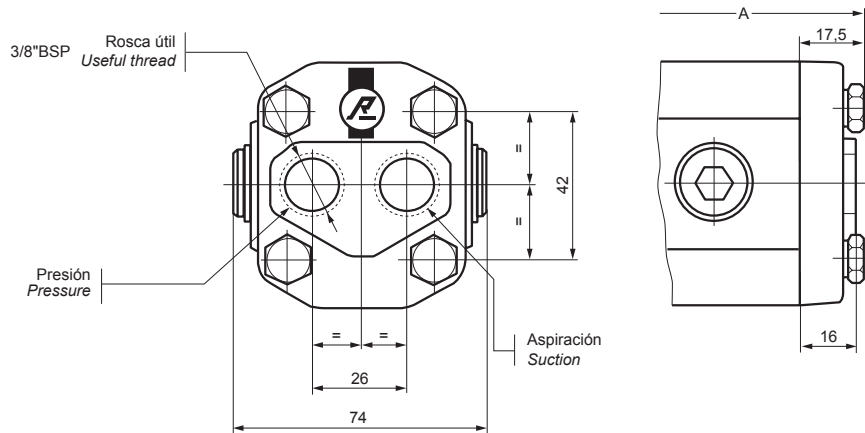

Tapa trasera con válvula limitadora
Back cover with relief valve

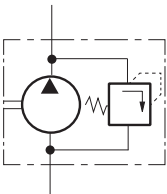
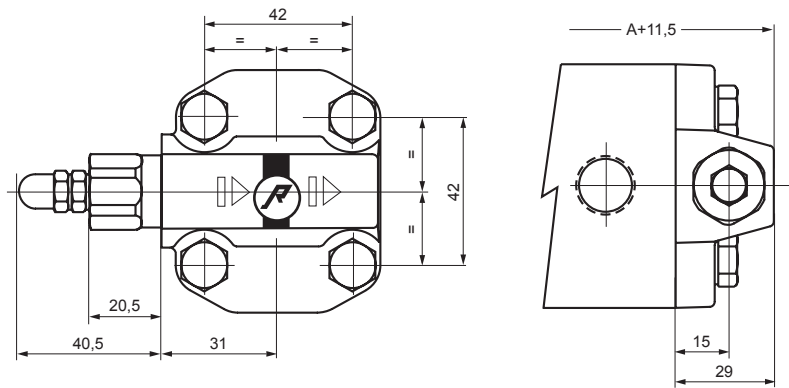

*Gama de presiones: 11 = 5-80 bar
*Pressure range: 12 = 80-175 bar
13 = 175-250 bar

Añadir al final de la Rfa. V* según taraje
Add to the code end of the V* reference according to taring

Tapa trasera con válvula antirretorno
Back cover with check valve

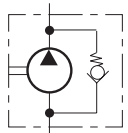
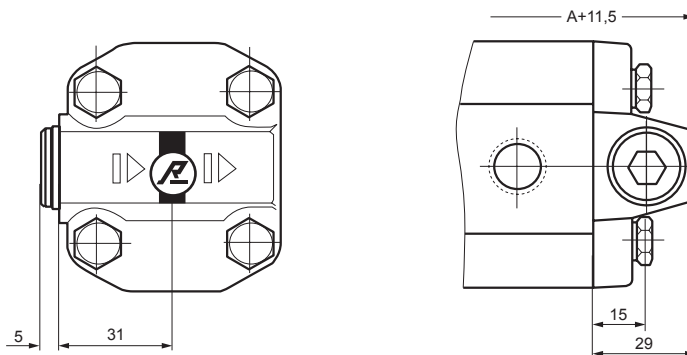

Añadir al final de la Rfa. ...VA)
Add to the code end: ...VA)

7 Con conexión tomas solo R
Side port connection form R only

Tapa trasera para bombas reversibles
Back cover for reversible pumps

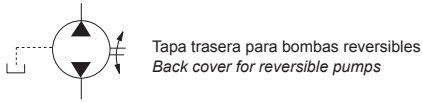
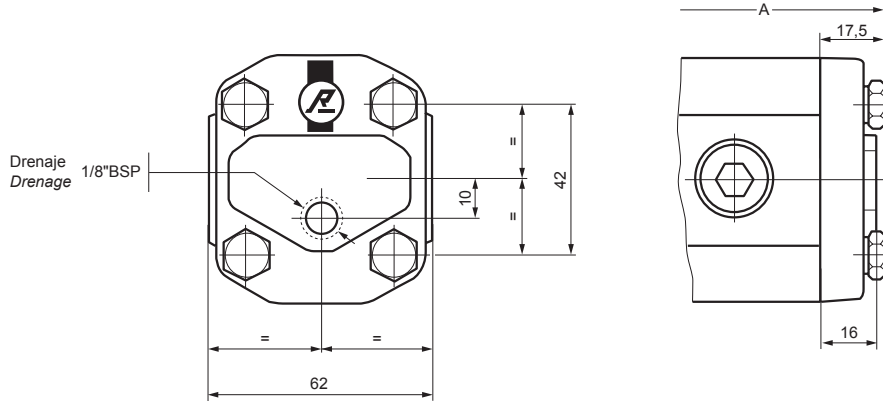

5 Diferentes tipos de poleas
Various types of pulley

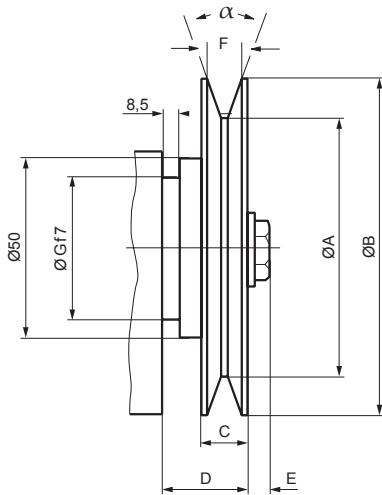

Tipo polea Pulley type	A	B	C	D	E	F	G	α	Tipo correa Belt type
P	76	100	14	27	4	10	72	36°	Z
R			17	28,5	3	13		34°	A

NOTA: Para medidas de fijación bomba ver tapa tipo 01 (pág. 6)
NOTE: For pump fixing dimensions see flange type 01 (page 6)

